



# BRANCH8 – COMPANY PROFILE

*A consulting and technologies service provider with in-depth e-Commerce expertise.*



# ABOUT BRANCH8

Branch8 specializes in

**Omni-channel e-Commerce**

consulting and technology services

**Clients**

Part of the **AppTask Group**

Served **500+** MNCs and Local Enterprises

Backed by:  **Combinator**

who also invested in:



and more

## OUR SPECIALTY



## WE SPECIALIZE IN...

- e-Commerce marketplace and systems integration
- Big data and machine learning applications
- Supply chain management system
- Warehouse management system
- Web and mobile app development
- Business & system workflow redesign

# HIGH LEVEL FEATURES

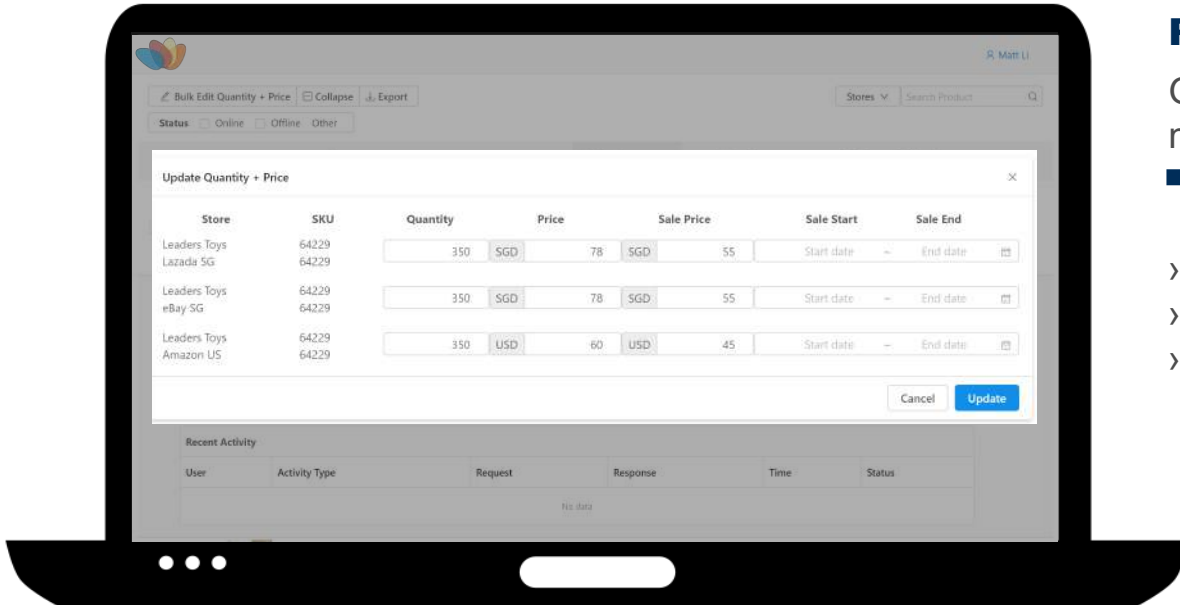

## PRODUCT MANAGEMENT

Group and manage products from multiple marketplace channels

- › Price / Stock Update
- › Bulk Edits
- › Promotion Periods



- › Create consistent product templates in bulk
- › Upload to marketplaces
- › Quality assurance workflow

## 1 Business Template

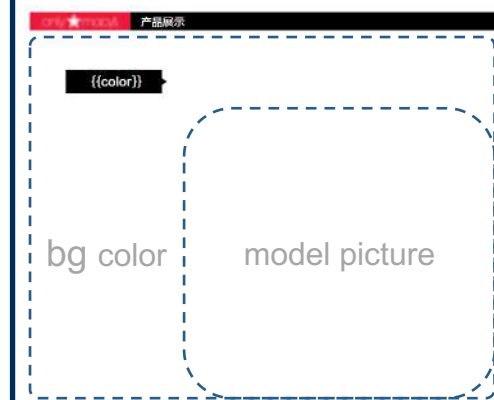

## 2 Create Content

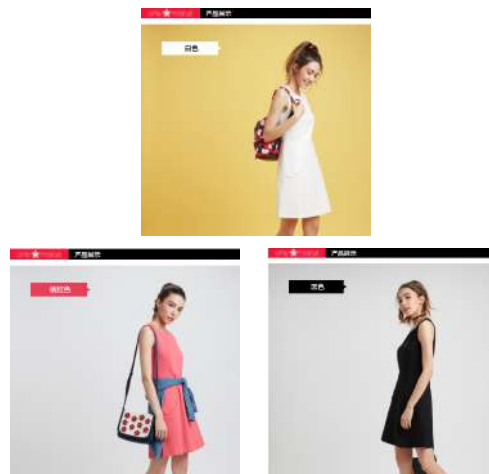

## 3 Marketplace Upload





## ORDER MANAGEMENT

Consolidate orders in a single interface

- › Third Party Logistics (3PL) integration
- › Update order status
- › Excel Exports
- › Returns management
- › ERP integration

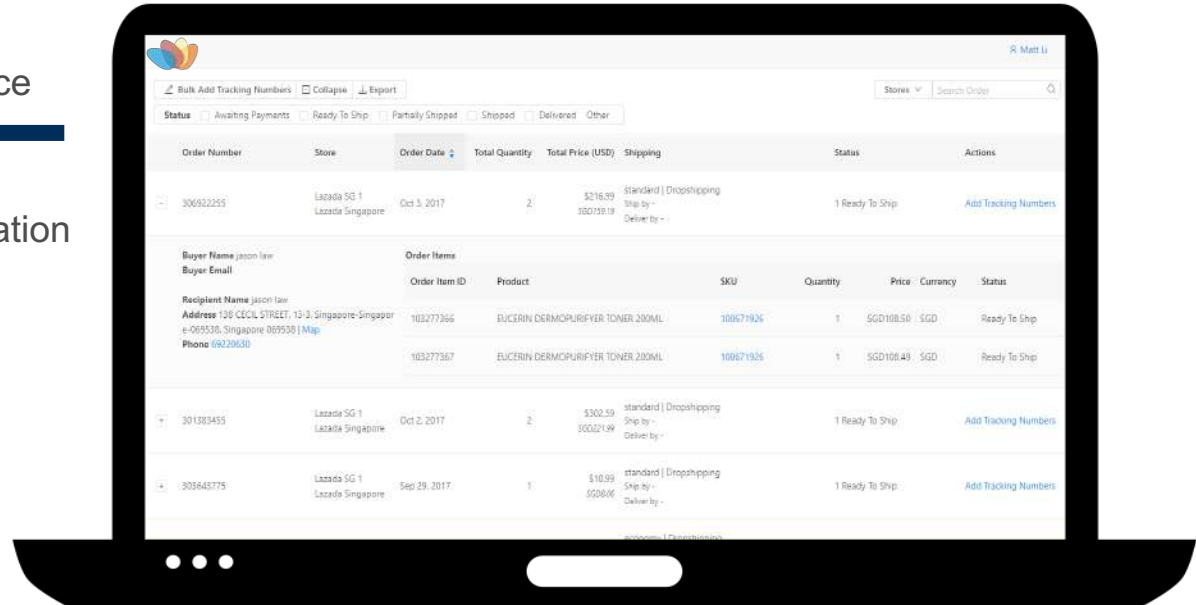

# PROJECT HIGHLIGHTS





# 3RD PARTY MARKETPLACE INTEGRATION

---

- **Tmall integration** for product description creation
- **Pre-listing quality control** for multi-team workflows
- **Product listing template creation** to build consistent product listings

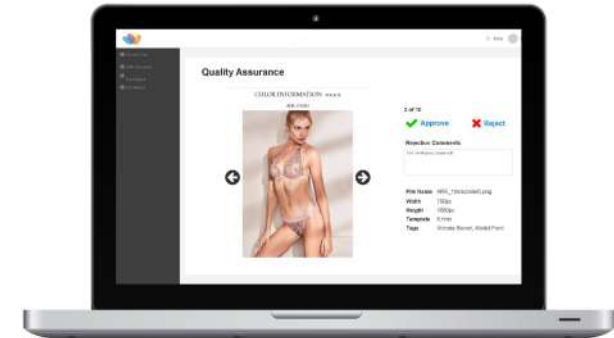
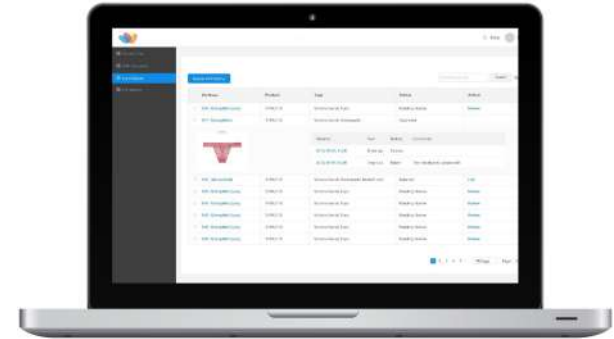



# ONLINE-TO-OFFLINE (O2O) PURCHASING SYSTEM

---

- Full featured transactional shopping cart site
- **Online** purchase, optional **Offline** pickup through QR code scanner
- **Enabled the client to easily add and remove products** to efficiently capture immediate sales

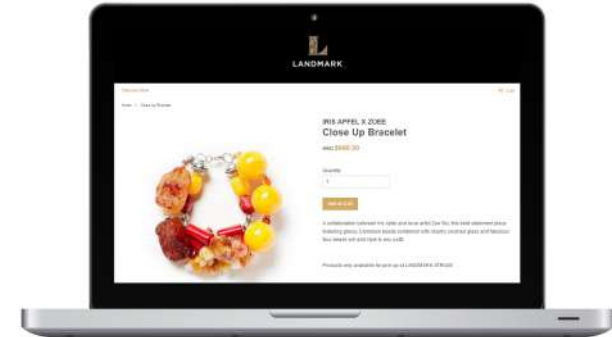



# MACHINE LEARNING PRODUCT RECOMMENDER

---

- **Product recommender** system to give customers tailored and timely product recommendation
- **Big data analysis** based on product details, consumer profile and sales data to increase revenue
- Applies to **offline** and **online** retailers

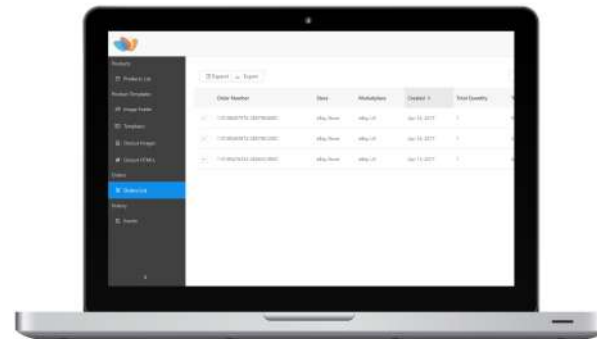
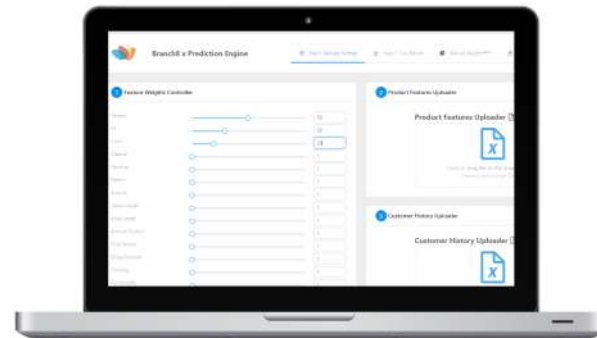



# PROCESS & SYSTEM WORKFLOW REDESIGN

- Analyze existing business and system process flow
- Define updated and/or new workflow to increase operational and system efficiency
- Develop control points to monitor process, feedback and implement improvements
- Prioritize and implement redesigned process and workflow with the client

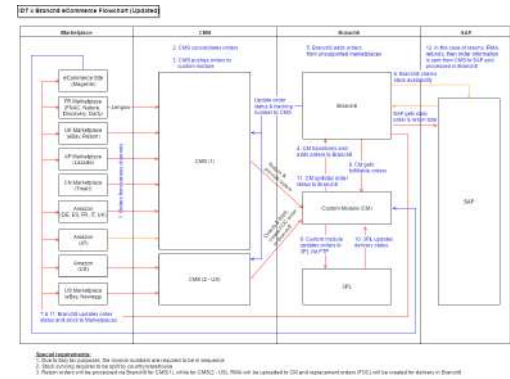
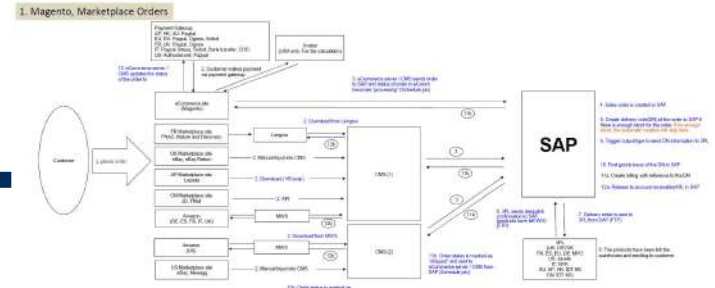



# FACEBOOK MESSENGER AI CHATBOT APP

---

- **First Facebook messenger food delivery chatbot** developed in Hong Kong
- **Automated ordering process** through AI technologies
- **Automated payment processor integration** to dashboard
- **Multi-channel customer and sales management** through integration with Facebook, Whatsapp and Email

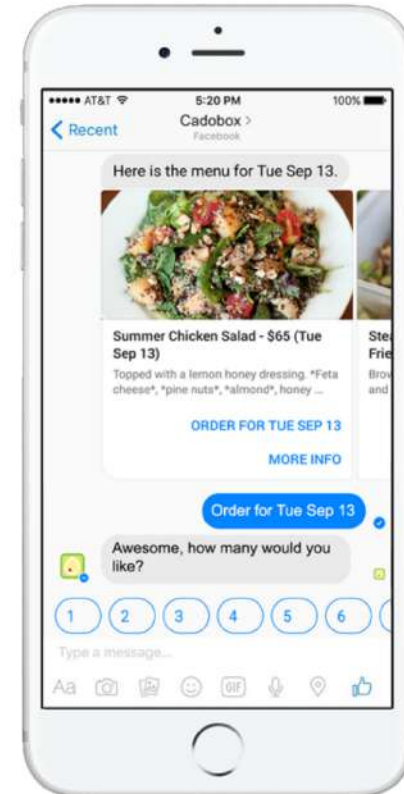

# **BRANCH8 TEAM**



**Matt Li**  
Team Leader

**Profile**

VP Corp. Banking – HSBC, HK



**Jackie Kong**  
Technical Lead

**Profile**

Program Manager – Microsoft, Seattle  
Analyst – Morgan Stanley, NYC  
Software Engineer – Facebook, SF



**Tim Mak**  
Project Manager

**Profile**

Head of Ops. – Sino Process, China



**Elton Chan**  
Engineering Sales

**Profile**

Head of Electronics – Lazada, HK  
Tech. Consultant – Accenture, HK



Venture Capital Investors



A M A S I A

Incu-Lab

Corporate Investors



Incubation Backers







- Branch8 has been featured on numerous international and local media outlets.



# THANK YOU FOR YOUR TIME!

Kindly get in touch to let us know if you have any questions.

[WWW.BRANCH8.COM](http://WWW.BRANCH8.COM)

+852 3487 6549

[WWW.ATGHOLDINGS.COM](http://WWW.ATGHOLDINGS.COM)

+852 9209 5794

UNIT B-D, 11/F  
16 CHEUNG YUE STREET  
CHEUNG SHA WAN  
KOWLOON, HONG KONG